

AdvancedTCA

Features



RITCA: Complex system solutions for ATCA, MicroTCA and AMC

From the outset, Rittal was decisively involved in the development of the ATCA standard, and offers a comprehensive product range for this platform: **RITCA**.

The new product generation comprises complete standard shelf solutions for ATCA and MicroTCA, including shelf management, backplane and cool-

ing concepts, fully wired and function-tested. The range is complemented by filler panels and face plates, as well as AMC/ATCA carriers in two variants.

The 13 U ATCA systems are equipped with the new hot-swap high-performance fans RiCool III.

These fans offer added output coupled with a reduced noise level. The backplane is a monolithic version with a high level of signal integrity in full mesh or dual star version. The systems are optionally available in a 2 or 4 PEM version.

B
3.1
AdvancedTCA



ATCA – Advanced Telecom Computing Architecture –

First cross-industry standard developed by PICMG (PCI Industrial Computer Manufacturers Group) to replace telecommunications applications previously developed on a proprietary basis. ATCA – The ideal solution for exacting demands in terms of system availability and performance, in both telecommunications and industrial automation, traffic control technology and medical technology. Rittal's product spectrum includes a range of complete systems in various designs with the corresponding accessories.

System benefits



- System availability of at least 99.999 %
- Fail safe maximised, thanks to redundancy
- Hot-swap capability ensures uninterrupted operation
- Transmission rates of up to 2.5 Tbit/s
- Large board formats: 8 U x 280 mm
- Switched fabric architecture
- By reducing proprietary platforms, the high cost of development and training is eliminated
- Available off the shelf
- Specified heat losses of up to 200 W per board
- Support of different protocols (Ethernet, Infiniband, Rapid I/O, PCI-Express)
- Defined performance up to 3.125 Gbit/s



Requirements according to PICMG 3.0

- 1 x system enclosure (mechanical system)
- Fans
- 48 V power entry modules (PEM)
- Installation space for 2 x shelf management controllers
- 1 x backplane for switched fabric and electrical distribution
- One shelf has either 14 or 16 slots
- A shelf with 14 slots is based on 19"
- A shelf with 16 slots is based on 23" or ETSI
- The height of a shelf is N x U or N x 25 mm (ETSI)
- The shelf depth is suitable for installation in 600 mm deep enclosures

Boards

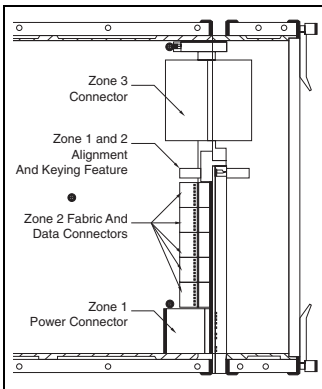

- Basic dimensions to IEC 60 297 and specific specifications to PICMG 3.0
- The front boards (8 U x 6 HP and 280 mm depth) contain the electronic functions and the connectors. They are offset from the pitch line by 6.61 mm and are 1.6 to 2.4 mm thick
- ESD contact clip on the component side 1
- Attachment holes for the cover of component side 2
- Essentially, a board type plug-in unit consists of a front panel with centering pin, EMC seal, injector/extractor handles with optional micro-switch operation for hot swap and M3-knurled screws.
- A cover is obligatory for component side 2 (rear) to reinforce the PCB and/or for EMC protection
- Rear I/O boards (RTM): 8 U x 6 HP x 70 mm

Connector zones

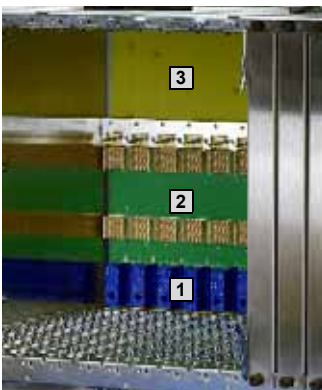

- Zone 1:** Power supply and system management
 - Zone 2:** Data communication
 - Zone 3:** RTM (rear I/O)
- Zone 1 and Zone 2 are equipped with a special centering/keying device.

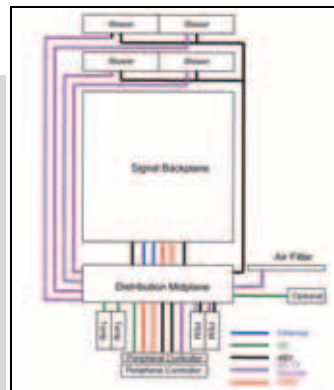

Shelf management

- Interfaces for the monitoring and control of:**
- Boards
 - PEMs (power entry modules)
 - Fans
 - Air inlet temperature
 - Remote alarm signals
 - Air filter available/not available

Shelf cooling

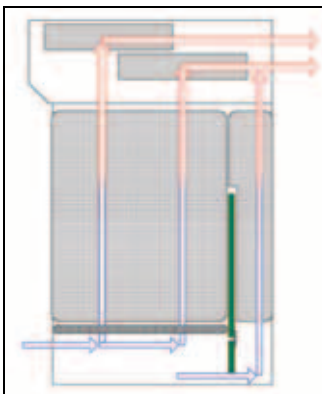

Side view, right



- ATCA specifies heat losses of up to 200 W per front board and 30 W per rear board, which translates into approximately 3 kW for a fully populated shelf with 14 boards.
- The four high-capacity RiCool fans from Rittal with 320 m³/h ensure optimum climatic conditions.
- Redundancy and hot-swap ensure reliability, even in the event of a fan failure.
- Replaceable dust filter in the air inlet zone.

Backplanes



- 3 times higher performance!**
- Full Mesh backplane from Rittal with 10 Gbit/s (acc. to PICMG, 3.125 Gbit/s required).

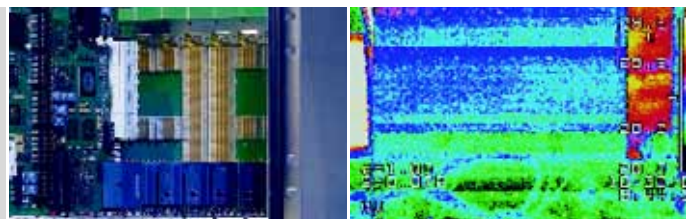

- Dual Intelligent Platform Management Interface (IPMI), bussed or radial (optional).
- Product range: Full Mesh, Dual Star, Dual Star also optionally available with additional Mesh performance.
- Thermal image of a Rittal backplane under full load.

AdvancedTCA shelf HS1, 5 U, 6 slots, horizontal, AC version

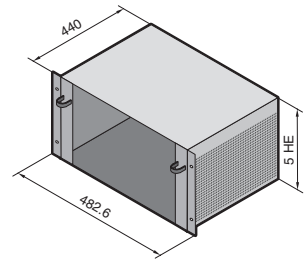

HE = U



Due to its compact design, the 5 U shelf version offers optimum application possibilities, e.g. as a test or development system, wherever high performance and a space-saving design is required.

Benefits at a glance:

- Conforms to PICMG 3.0 rev. 2.0
- Hot swap-compatible fan units
- Specified heat loss of at least 200 W/board
- System monitoring using Shelf Management Controllers (ShMC)
- Plug & play-compatible for ShMC, Intel WT or PP 500
- Fully assembled, wired and function tested

Technical specifications:

- 19", 5 U, 440 mm deep
- 6 slots (horizontal) at the front, including 2 switch slots with RTM
- Cooling of up to 200 W/slot (front area)
- Cooling of up to 30 W/RTM
- Hot-swap fan unit
- Pull-out filter
- Voltage supply 90 – 264 V AC, 1000 W
- Including 1 Shelf Management Controller (ShMC) Pigeon Point 500 or Intel WT
- Full Mesh backplane (repliated Mesh) or Dual Star

Supply includes:

- 1 rack-mount system 482.6 mm (19"), 5 U, 440 mm deep,
- 2 fan units each with 7 fans,
- 1 backplane, 6 slots,
- 1 ShMC Pigeon Point 500 or Intel WT,
- 1 AC/DC PSU.



Accessories:

Shelf Management Controller, ATCA face plate kit, see page 491.

Standard AdvancedTCA Shelf HS1 (ShMC connectable from the front), available off the shelf

Shelf	U	Slots	Backplane	IPMI	ShMC	Switch Slots	PSU	Model No. RP
HS1	5	6	Dual Star	Bus topology	Pigeon Point 500	1 + 2	AC/DC, 1000 W	9910.732
HS1	5	6	Full Mesh	Bus topology	Pigeon Point 500	1 + 2	AC/DC, 1000 W	9911.713
HS1	5	6	Dual Star	Bus topology	Intel WT	1 + 2	AC/DC, 1000 W	9911.712
HS1	5	6	Full Mesh	Bus topology	Intel WT	1 + 2	AC/DC, 1000 W	9911.714

Accessories

	Country version	Voltage V	Model No. DK/RP
Mains connection cable C19/IEC320, up to 16 A	D/F/B	230	7200.216
	GB	230	9911.859
	USA/CDN	115	9911.860
	China	230	9911.861
IEC320 extension C19/C20	Country-independent	115/230	7200.217

Example of possible customised applications available on request

Version	U	System enclosures	ShMC/ Intel WT	ShMC/ Pigeon Point 500	Filler panel	Fan unit	Backplane Full Mesh	Backplane Dual Star
1	5	■	■	–	■	1	■	–
2	5	■	■	–	■	1	–	■
3	5	■	–	■	■	1	■	–
4	5	■	–	■	■	1	–	■

■ Included with the supply.

Note:

The ATCA systems are based on standard components which may be individually combined in accordance with a modular principle.

The above matrix provides an overview of additional installation variants based on the described systems which may be implemented in a short lead time.

AdvancedTCA shelf HS1, 5 U, 6 slots, horizontal, DC version

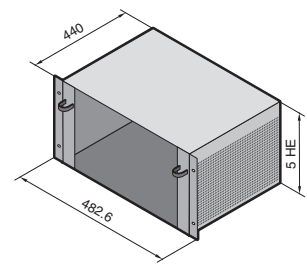
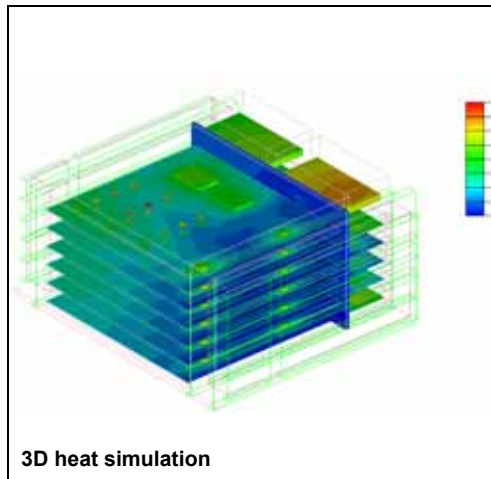
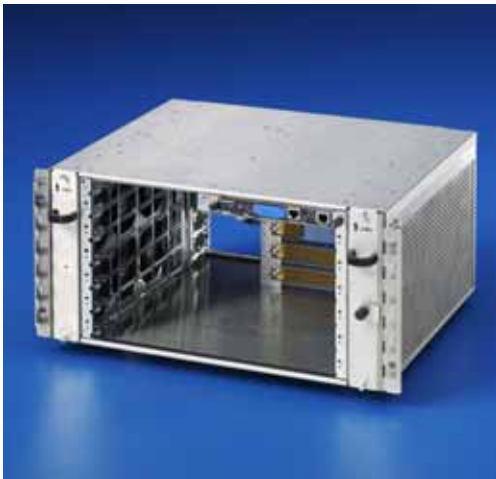

HE = U



Due to its compact design, the 5 U shelf version offers optimum application possibilities, e.g. as a test or development system, wherever high performance and a space-saving design is required.

Benefits at a glance:

- Conforms to PICMG 3.0 rev. 2.0
- Hot swap-compatible fan units
- Specified heat loss of at least 200 W/board
- System monitoring using Shelf Management Controllers (ShMC)
- Plug & play-compatible for ShMC, Intel WT or PP 500
- Fully assembled, wired and function tested

Technical specifications:

- 19", 5 U, 440 mm deep
- 6 slots (horizontal) at the front, including 2 switch slots with RTM
- 5 slots (horizontal), RTM
- Cooling of up to 200 W/slot (front area)
- Cooling of up to 30 W/RTM
- Hot-swap fan unit
- Pull-out filter
- Including 1 Shelf Management Controller (ShMC) Pigeon Point 500 or Intel WT
- Full Mesh backplane (replicated Mesh) or Dual Star
- DC PEM 50 A with filter and controller

Supply includes:

- 1 rack-mount system 482.6 mm (19"), 5 U, 440 mm deep,
- 2 fan units each with 7 fans,
- 1 backplane, 6 slots,
- 1 ShMC Pigeon Point 500 or Intel WT,
- 2 PEM 50 A.



Accessories:

Shelf Management Controller, ATCA face plate kit, see page 491.

Standard AdvancedTCA Shelf HS1 (ShMC connectable from the front), available off the shelf

Shelf	U	Slots	Backplane	IPMI	ShMC	Switch Slots	PEM	Model No. RP
HS1	5	6	Dual Star	Bus topology	Pigeon Point 500	1 + 2	2 x 50 A	9911.715
HS1	5	6	Full Mesh	Bus topology	Pigeon Point 500	1 + 2	2 x 50 A	9911.717
HS1	5	6	Dual Star	Bus topology	Intel WT	1 + 2	2 x 50 A	9911.716
HS1	5	6	Full Mesh	Bus topology	Intel WT	1 + 2	2 x 50 A	9911.718

Example of possible customised applications available on request

Version	U	System enclosures	2 x DC PEM 50 A	2 x DC power connection with 50 A fuse switch	ShMC/ Intel WT	ShMC/ Pigeon Point 500	Filler panel	Fan unit	Backplane Full Mesh	Backplane Dual Star
1	5	■	■	-	■	-	■	1	■	-
2	5	■	■	-	■	-	■	1	-	■
3	5	■	■	-	-	■	■	1	■	-
4	5	■	■	-	-	■	■	1	-	■
5	5	■	-	■	■	-	-	2	■	-
6	5	■	-	■	■	-	■	1	■	-
7	5	■	-	■	■	-	-	2	-	■
8	5	■	-	■	■	-	■	1	-	■
9	5	■	-	■	-	■	-	2	■	-
10	5	■	-	■	-	■	■	1	■	-
11	5	■	-	■	-	■	-	2	-	■
12	5	■	-	■	-	■	■	1	-	■

■ Included with the supply.

Note:

The ATCA systems are based on standard components which may be individually combined in accordance with a modular principle.

The above matrix provides an overview of additional installation variants based on the described systems which may be implemented in a short lead time.

AdvancedTCA

AdvancedTCA shelf VS1, 13 U, 14 slots

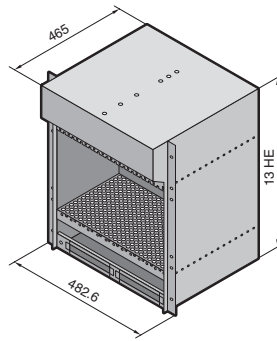

HE = U



Benefits at a glance:

- Conforms to PICMG 3.0 rev. 2.0
- Hot swap-compatible, redundant fans for cooling of min. 200 W/board
- Plug & play-compatible for ShMC, Intel WT or PP 500
- System monitoring using Shelf Management Controllers (ShMC)
- Fully assembled, wired and function tested

Technical specifications:

- 19" x 13 U x 465 mm (+ 40 mm projection at the rear for PEM) deep
- 14 x 6 HP slots for front boards and RTM
- 14 slots Dual Star or Full Mesh backplane with "bussed" IPMI (optionally radial)
- 4 x rear-connected PEM, 48 V DC, 50 A
- Prepared for 2 x front-connecting ShMC/Intel WT or Pigeon Point 500 (1 x ShMC is included with the supply)

- Space for rear telecom service connection
- RiCool fans connected via the front (4 fans each with 320 m³/h, dual IPMI)
- Filter frame connected at the front (with air baffle plate and filter mat)
- Optional cable ducts for front and rear

Supply includes:

- 1 rack-mount system 482.6 mm (19"), 13 U, 465 mm deep,
- 4 RiCool fans,
- 1 backplane, 14 slots,
- 4 redundant power entry modules (PEM), 48 V,
- 1 Shelf Management Controller (ShMC).



Accessories:

see page 491.

Detailed drawing,
see page 1264.

Standard AdvancedTCA Shelf VS1 (ShMC connectable from the front), available off the shelf

Shelf	U	Slots	Backplane	IPMI	ShMC	Switch Slots	PEM	PEM-Amp	RiCool-III	Model No. RP
VS1	13	14	Dual Star	Bus topology	Pigeon Point 500	1 + 2	4 x	50 A	4 x 48 V-IPMI	9910.932
VS1	13	14	Full Mesh	Bus topology	Pigeon Point 500	1 + 2	4 x	50 A	4 x 48 V-IPMI	9910.933
VS1	13	14	Dual Star	Bus topology	Intel WT	1 + 2	4 x	50 A	4 x 48 V-IPMI	9910.940
VS1	13	14	Full Mesh	Bus topology	Intel WT	1 + 2	4 x	50 A	4 x 48 V-IPMI	9910.941

Example of possible customised applications available on request

Version	System enclosures	4 x PEM 50 A	2 x PEM 100 A	ShMC/Intel WT	ShMC/ Pigeon Point 500	Backplane Full Mesh	Backplane Dual Star
1	■	–	■	■	–	■	–
2	■	–	■	■	–	–	■
3	■	–	■	–	■	■	–
4	■	–	■	–	■	–	■

■ Included with the supply.

Note:

The ATCA systems are based on standard components which may be individually combined in accordance with a modular principle.

The above matrix provides an overview of additional installation variants based on the described systems which may be implemented in a short lead time.

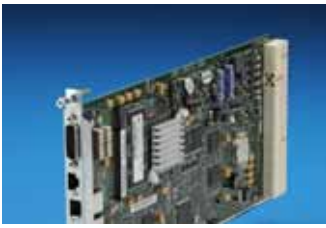

Shelf Management Controller (ShMC)

- Up to 2 Shelf Managers may be used per system
- Technology: Intel Wagonfire or Pigeon Point 500

Design	Packs of	Model No. RP
Pigeon Point 500	1	9910.570
Intel Wagonfire	1	9910.942



ATCA face plate kit

- With integral cover for component side 2 and for board attachment
- Including foam EMC seal (stick-on)
- Including hot-swap injector/extractor handles
- Customer-specific machining and marking available on request

Material:
Stainless steel

Supply includes:
1 face plate, 2 handles, EMC seal, mounting screws.

Description	U	HP	Packs of	Model No. RP
1 Face plate front	8	6	1	9906.693
2 Face plate rear	8	6	1	9910.379

EMC

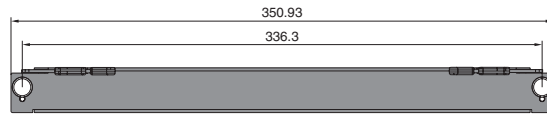
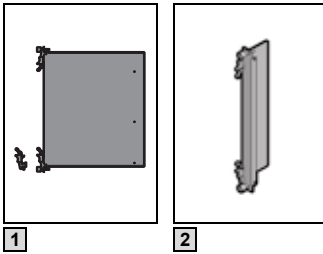

Face plate



Handle/microswitch

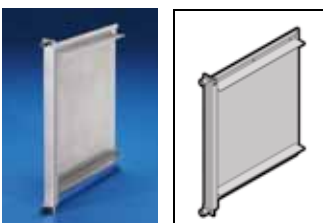
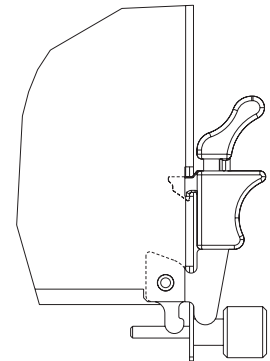

ATCA filler panel kit

- To conceal unused slots
- Optionally with or without air routing
- Including foam EMC seal (stick-on)

Material:
Stainless steel

Supply includes:
1 face plate, EMC seal, mounting screws.

Description	U	HP	Packs of	Model No. RP
1 Face plate front with air routing	8	6	1	9906.694
2 Face plate rear with air routing	8	6	1	9910.185
3 Face plate front/rear without air routing	8	6	1	9910.380

EMC

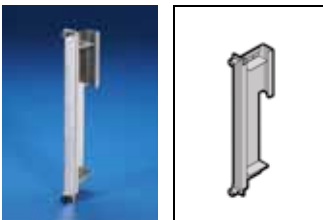

3

ATCA/AMC carrier blade



ATCA/AMC.1 and 2 from Rittal are ATCA carrier blades with 2 – 4 AMC slots depending on the required AMC form factor. With carrier blades, the emphasis is on giving users the maximum possible flexibility with the use of AMC technology. Depending on the required application, various processor AMCs may be combined with memory AMCs and interface AMCs in order to develop and configure individual systems based on the ATCA standard from the various standard AMCs using ATCA/AMC carriers.

2 standard ATCA/AMC carrier blades have been developed for the various applications in telecommunications and the IT industry which support the most widespread communication protocols GbE (AMC.2) and PCIe (AMC.1).

The carriers meet the specifications of PICMG 3.0/3.1.

B
3.1

AdvancedTCA

AdvancedMC carrier ATCA/AMC.1

The serial interfaces for all AMC slots meet the specifications of AMC.2 type E2 (GbE for the Common Option Region) and AMC.1 Type 4 (PCIe for the Fatpipe Region), whereby 1 AMC slot additionally conforms to AMC.1 type 8. The 2 GbE ports for the Common Region (AMC.2 type E2) are used for control functions and data transfer, as well as for backup requirements. Each PCIe and GbE port in the AMCs is connected to a non-blocking switch for maximum performance. Additionally, all AMC slots are likewise AMC.3 compatible (port 2 and 3) to support applications requiring storage media such as SAS/SATA. The ATCA/AMC.1 carrier is designed for CARRIER GRADE SERVICES.

AdvancedMC carrier ATCA/AMC.2

The serial interfaces for all AMC slots conform to the specification AMC.2 type E2 (GbE for the Common Option Region) as well as AMC.2 type 4 (Port 4-7 for the Fatpipe Region). The 2 GbE ports for the Common Region (AMC.2 type E2) are used for control functions and data transfer, as well as for backup requirements. Each GbE port in the AMCs is connected to a non-blocking switch for maximum performance. Additionally, all AMC slots are likewise AMC.3 compatible (Ports 2 and 3) to support applications requiring storage media such as SAS/SATA. The ATCA/AMC.2 carrier is designed for CARRIER GRADE SERVICES.

IPMI (Intelligent Platform Management Interface) & hot swap functionality

The Management Controller on the ATCA/AMC carrier blade supports IPMI functions to Version 1.5 including e-keying, modular power management and distribution, system clocks and hot swap functionality. E-keying allows the carrier to identify which AMC slots are assigned in order to configure the fabric interfaces accordingly. The ATCA/AMC .1 or .2 carrier blade is hot swap-compatible to PICMG 3.0 and may be exchanged with the system operational.

ATCA/AMC carrier blade

ATCA/AMC.1 carrier

Model No. RP	9908.499
Form factor	PICMG 3.0
AMC slots	4 x AMC single full-size to AMC.0 R2
AMC protocol support	AMC.1 type 4 (Port 4 – 7) AMC.1 type 8 on slot 2 (Port 4 – 11) AMC.2 type E2 (Port 0 – 1) AMC.3 (Port 2 – 3)
IPMI support	IPMI V1.5 upgradeable
ATCA protocol support	2 Port GbE base interfaces 4 Port GbE fabric interfaces

Electricity consumption	max. 160 W for AMC bays max. 40 W for carrier max. 30 W for RTM
Weight	1.6 kg (3.5 lbs)
Operating temperature	-5°C to +55°C
Storage temperature	-40°C to +85°C
Humidity	5 – 95 %
Approvals	CE

ATCA/AMC.2 carrier

Model No. RP	9911.705
Form factor	PICMG 3.0
AMC slots	4 x AMC single full-size to AMC.0 R2, APS and Zone 3 RTM
AMC protocol support	AMC.2 type 4 (Port 4 – 7) AMC.2 type E2 (Port 0 – 1) AMC.3 (Port 2 – 3)
IPMI support	IPMI V1.5 upgradeable
ATCA protocol support	2 Port GbE base interfaces 4 Port GbE fabric interfaces

Electricity consumption	max. 160 W for AMC bays max. 40 W for carrier max. 30 W for RTM
Weight	1.6 kg (3.5 lbs)
Operating temperature	-5°C to +55°C
Storage temperature	-40°C to +85°C
Humidity	5 – 95 %
Approvals	CE

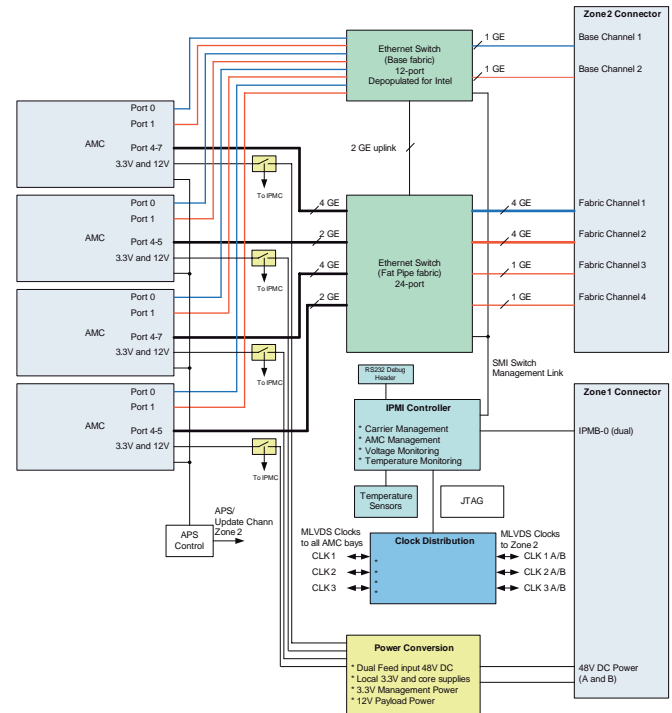
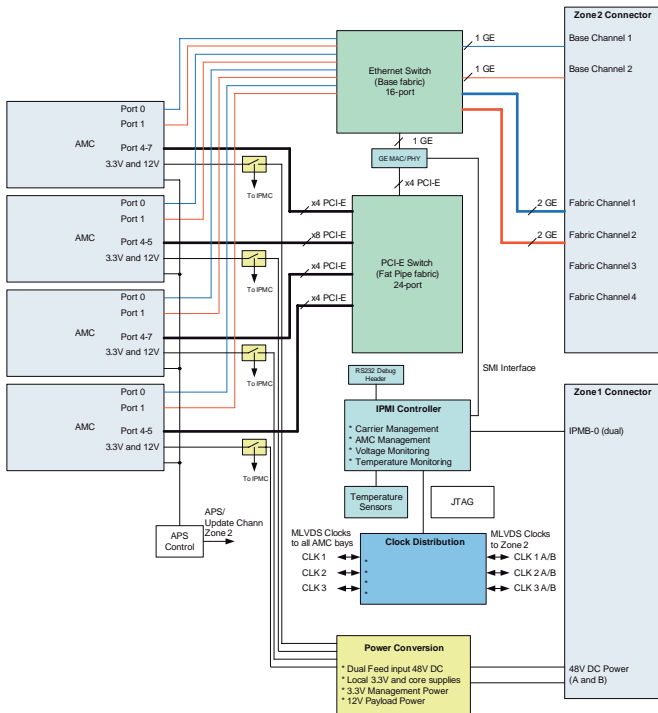

Face plates



AdvancedMC face plate kits

These are used as face plates for AMC cards and ATCA carriers, or as filler panels in MicroTCA systems.

- Installation in μ TCA systems or AMC carriers
- Conforms to AMC.0 R2.0
- Height: Single & Double
- Widths: Compact, Mid-Size, Full-Size
- Simple handling when locking and unlocking (no screws)
- Hot swap-compatible injector/extractor handles
- Customer-specific face plates available with a short lead time
- Upgradable with filler sheets and air baffle plates
- Double to Single conversion module (accessory)

Material:

Face plate made from aluminium, bare (stainless steel available on request)
 Holder for light pipe and PCB, die-cast Zn
 Light pipe, polycarbonate
 Handle, die-cast Zn, spray-finished
 EMC seal, foam with metal fabric (UL 94 V0)

Supply includes:

- 1 U-channel face plate,
- 1 holder to accommodate a light pipe and PCB,
- 1 handle for microswitch,
- 1 light pipe (for 2 LEDs),
- 1 EMC gasket, left side and bottom.

Design (H x W)	Packs of	Model No. RP
Single x Compact	1	9911.885
Single x Mid-Size	1	9911.889
Single x Full-Size	1	9911.886
Double x Compact	1	9911.887
Double x Mid-Size	1	9911.890
Double x Full-Size	1	9911.888

Face plates with 4 LEDs in aluminium and stainless steel available on request (to AMC.0 Spec. R1.0).

+ Accessories:

AMC filler sheets, air baffle plates, conversion module, see page 495.

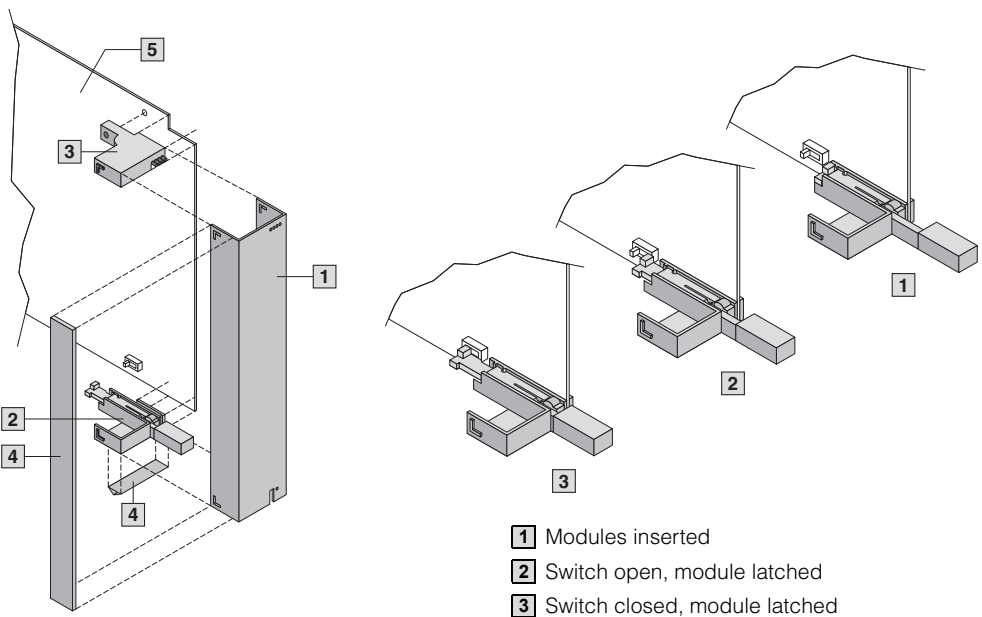

- 1** Face plate
- 2** Handle and locator for PCB
- 3** Holder with LED light pipe and locator for PCB
- 4** EMC gaskets
- 5** Filler sheet

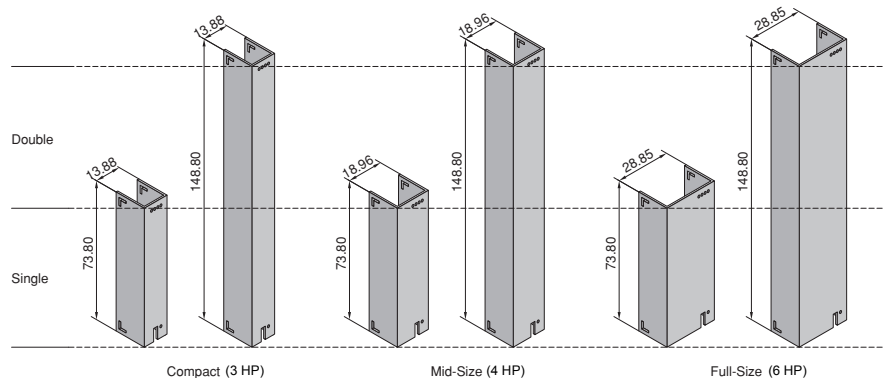

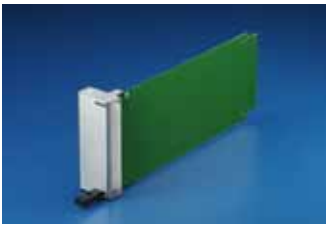

AMC filler sheets

Filler sheets are mounted on the AMC face plates and are used to route the airflow in ATCA carriers and MicroTCA systems. They may additionally be equipped with air baffle plates to create suitable air resistance in an empty slot.

Material:
FR4



Design	Packs of	Model No. RP
Single	1	9911.570
Double	1	9911.571



Air baffle plates

AMC slots must be populated with an empty card in order to ensure adequate air resistance. The air resistance should be adapted to the requirements of the overall system by the user. In all cases, it should be sufficiently high to ensure that the air is forced to flow over active cards into adjacent slots and does not flow unhindered through empty slots. The air baffle plate is used to adjust the air resistance. Up to 2 air baffle plates may be mounted on one filler sheet. Adjustable air resistance from 80 – 50 % thanks to removable membranes.

Material:
Stainless steel

Supply includes:
1 baffle plate, assembly parts



Design	Packs of	Model No. RP
Compact	1	9911.891
Mid-Size	1	9911.892
Full-Size	1	9911.893



Conversion module

The conversion module allows 1 x Double to be converted into 1 x Single slot. Option of installing Compact or Full-Size modules.

Material:
Stainless steel, partially spray-finished

Supply includes:
1 conversion module



Design	Packs of	Model No. RP
Compact	1	9907.699
Full-Size	1	9911.220

Development systems/rack-mount systems



MicroTCA development systems for hardware and software development or testing of AMC modules

Technical specifications:

- Complies with PICMG MicroTCA.0 R1.0 and AMC.0 R2.0
- 482.6 mm (19") development systems in 3 and 5 U, 200 mm deep for installing Single or Double AdvancedMC modules
- Integral fan unit for cooling up to 40 W/slot
- Including backplane, 14 slots

- Integral power adaptor
- Fully wired and tested

MicroTCA rack-mounted system for applications in the low-end telecommunications and industry sectors.

Technical specifications:

- Complies with PICMG MicroTCA.0 R1.0 and AMC.0 R2.0
- 482.6 mm (19") rack-mounted systems in 2 and 4 U, 200 mm deep for installing Single or Double AdvancedMC modules

- Including backplane, 14 slots
- Fully wired and tested
- Order climate control units separately

Material:

Rack-mount systems of sheet steel, zinc-plated, passivated

Supply includes:

- 1 482.6 mm (19") system, 200 mm deep,
- 1 backplane,
- 1 fan unit,
- additional development system,
- 1 power adaptor,
- 2 support brackets.

MicroTCA development systems

μTCA system	U	Slots	MCH slots	Power adaptor	Model No. RP
VP 1	3	12	2	1	9911.297
VP 1	5	12	2	1	9911.298

Power modules available on request.

MicroTCA rack-mount systems

μTCA system	U	Slots	MCH slots	Model No. RP
VP 1	2	12	2	available on request
VP 1	2 + 10 mm	12	2	9911.758
VP 1	4	12	2	9911.760

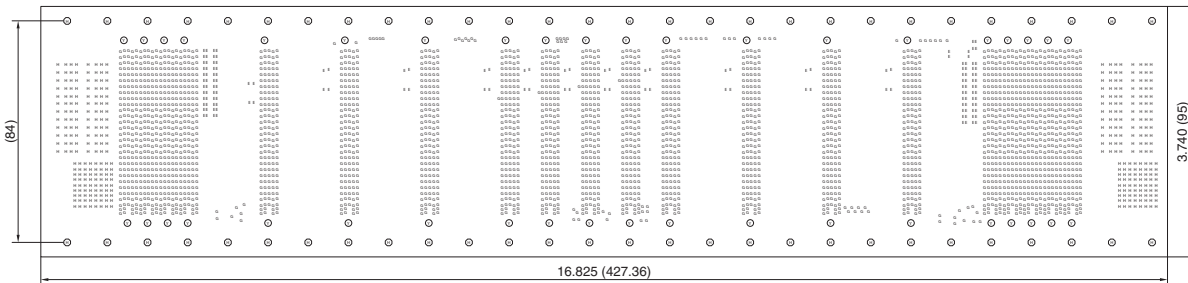

Power adaptor

For commissioning or testing μTCA systems, including front connection terminal. Power adaptors may be installed directly in 2 and 3 U μTCA systems. For installation in 4 and 5 U systems, a conversion module is also required.

Technical specifications:

- 12 V input
- 12 V output
- 3.3 V output

Packs of	Model No. RP
1	9911.380 ¹⁾

¹⁾ For 4 and 5 U MicroTCA you will additionally need to order a conversion module Model No. RP 9911.220, see page 495.

PicoTCA, 482.6 mm (19"), 2 U

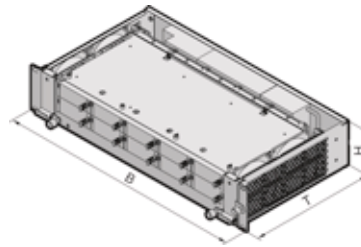
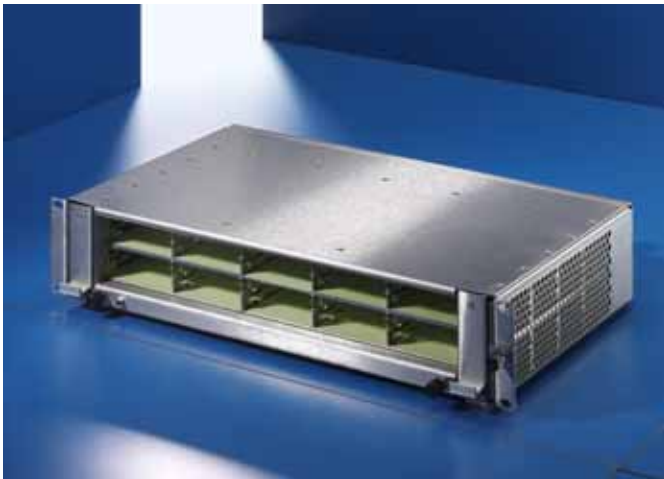

The PicoTCA is a modular 19" chassis in 2 U design supporting up to 12 AMCs and an MCH (full-size, compact). The chassis is designed such that communication protocols compliant with AMC.1 type 4 (PCIe and Advanced Switching), AMC.2 type 4, AMC.2 E2 (GbE) and AMC.3 (SAS/SATA) can all be handled. For SAS and SATA AMC boards, a point-to-point connection is realised via the backplane, so that each slot is able to communicate directly with its neighbouring slots via ports 2 and 3. In the initial version, an MCH (MicroTCA Carrier Hub) is supported via the backplane. Customer-specific designs and backplanes can be supplied upon request.

Benefits at a glance

- Conforms to PICMG MicroTCA.0 R1.0
- Extremely compact ready-to-run system
- Chassis depth of 254 mm for installation in 300 mm deep enclosures
- Includes AC/DC power supply
- Support for up to 12.5 Gb/s
- Support for different AMC form factors
- Exchangeable air filters
- High EMC shielding
- Robust industrial design ensures minimum sensitivity to impact and vibration
- NEBS-compliant
- Fully assembled, wired and tested. Ready to run

Technical specifications:

- 19", 2 U, 254 mm deep
- AC/DC power supply, max. 450 W:
 - Input voltage: min. 90 V AC – max. 264 V AC with PFC
 - Input frequency: min. 47 Hz – max. 63 Hz
 - Output: 3.3 V DC/max. 3 A, 12 V DC/max. 38 A
- Cooling via 2 independent fan trays
- Backplane and AMC connectors in **con:card+** quality from HARTING
- Integrated JTAG connector for debugging and testing

- Supports 12 AMCs (full-size, compact) compliant with AMC.1 type 4 E2S and AMC.2 type 4 E2S, as well as 1 MCH
- Weight: 9 kg
- Operating temperature: 0°C to +45°C
- Storage temperature: –40°C to +85°C

Supply includes:

- 1 rack-mount system 482.6 mm (19"), 2 U, 254 mm deep,
- 2 fan tray modules with air filters,
- 1 power supply,
- 1 backplane.

	Packs of	2 U
Width (B)		19"
Height (H) mm		89.4
Depth (T) mm		254
Model No. RP	1	9911.803

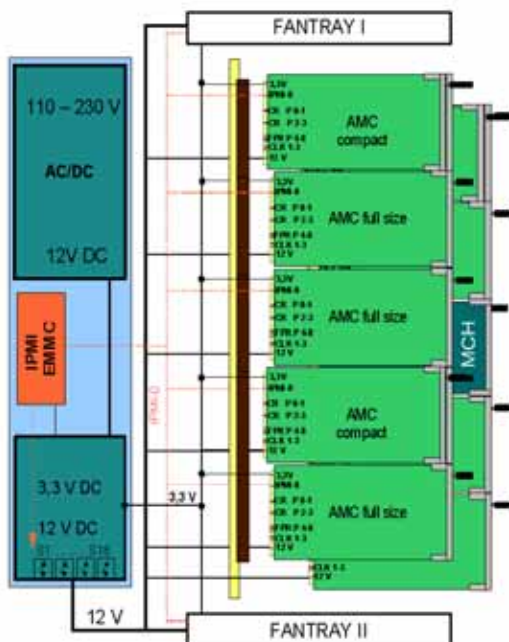

AdvancedTCA climate control solutions

Features



One of the major challenges posed by AdvancedTCA systems is heat management. The ATCA specification defines a heat loss of 200 W per slot. This means that a single ATCA shelf with 14 populated slots already has a maximum total heat loss of 2.8 kW, and the heat loss in an enclosure with three populated systems may therefore rise to more than 10 kW. Moreover, with clock frequencies likely to rise to the upper two-figure GHz range in the near future, the current methods of air cooling will struggle or even be completely unable to deal with the heat loss arising. In order to find a suitable solution, we need to face up to this situation now.

As one of the leading manufacturers of climate control solutions, Rittal offers holistic concepts, from CPU cooling, to shelf cooling, through to complete rack cooling with an output of up to 12 kW.

Shelf cooling

For the majority of applications, air cooling is the preferred option. A distinction is made between push cooling and pull cooling. In push cooling, axial or diagonal fans press cold air into the system. In pull cooling, fans draw hot air out of the system. Due to the confined space and integration density, the pressure losses caused by ATCA

cards are very high. Standard axial fans in a push or pull configuration are less suitable, because they can cave in as the back-pressure rises. By contrast, radial fans specialise in these types of applications, although the throughput is slightly lower in free air.



ATCA specifies heat losses of up to 200 W per front board and 30 W per rear board, which translates into approximately 3 kW for a fully populated shelf with 14 boards.



The four high-capacity RiCool fans from Rittal with 320 m³/h ensure optimum climatic conditions. Including IPMB interface.

The redundancy and hot-swap features ensure reliability, even in the event of a fan failure (FRU). Replaceable dust filter in the air inlet zone.

CPU cooling

Cooling fluids benefit from the physical property of having a specific thermal capacity several times higher than air. As a result, it is possible to design very small cooling systems with a maximum cooling

capacity and position them directly at the point of origination (e.g. processors). This helps to minimise the threat of hotspots which dramatically shorten the service life of electronics.



Liquid connection – via simple insertion. When the card is inserted, board cooling is automatically integrated into the cooling circuit.



Reliable discharge of 70 % of heat loss. Up to 250 W per cm² at the hotspot.



Rapid board exchange without hose couplings. Horizontal distributor integrated into the shelf.

3.1 B AdvancedTCA climate control solutions

Rack cooling

For the climate control of fully configured enclosures, there are several factors which need to be taken into account: The even distribution of chilled air, full accessibility to the 482.6 mm (19") level, plus the investment safeguards of on-demand expandability and remote

monitoring facilities. It should be possible to optimise the cooling output to the actual demand. Fully configured enclosures with ATCA systems can often push air cooling systems to their limits. Instead, complex air/water solutions are needed.



LCP (Liquid Cooling Package)



The Rittal LCP (Liquid Cooling Package) solves the problem of high heat losses with scalable cooling via air/water heat exchangers as a climate control enclosure on the side panel of a rack.

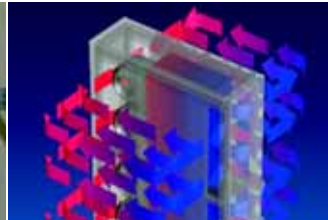

Individual ATCA shelves, as well as fully configured enclosures, can be cooled according to output.

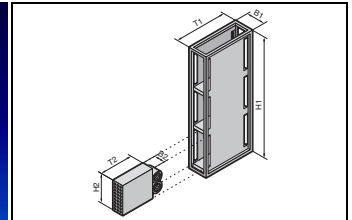

Modular, upgradable and temperature-neutral cooling concept. 12 kW cooling output, with three cooling modules supported per cooling rack.



CCP (Compact Cooling Package)



CCP is a full climate control package comprising:

- **Controller-managed 19" air/water heat exchanger**
- **Rack-mounted fan module**
- **300 mm deep 19" enclosure**
- **and an optional recooling unit**

Technical specifications:

- 482.6 mm (19"), 260 mm, 1 U rack-mounted heat exchanger
- PWM-controlled fans
- Cooling unit can be controlled via a processing unit (PU)
- System availability of 99.999 %



CCP can be configured and adapted individually to match specific application needs. It provides for effective and affordable cooling of the boards installed in vertically mounted electronics racks, and is

- Remains available even in case of a fan failure or temperature deviations (55°C for 96 h)
- Hot swap-compatible fan units
- Fully wired and tested



supplied with a robust controller and sensors for automatic and reliable control of the system.

- Suitable also for altitudes up to 1800 metres above sea level
- Low noise (sound power level 6.0 bels; 2 fan units @Stand-airair)
- Supports IPMI and CMC-TC protocols

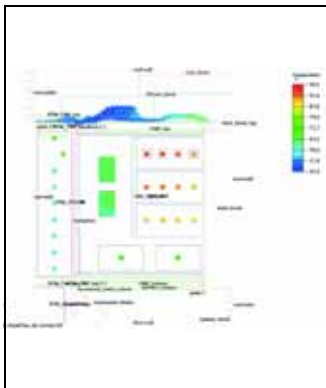

CFD (Computational Fluid Dynamics)

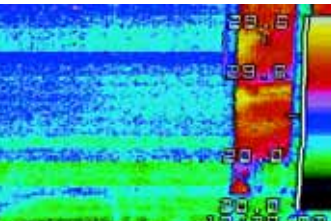

With the aid of CFD, climate control solutions may be optimised even before the first prototype has been built.

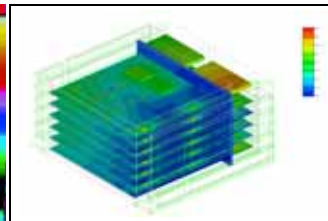

The Rittal portfolio of services includes:

- Visualisation of temperature variations
- Visualisation of air flows
- Localisation and elimination of hotspots

- Targeted optimisation of climate control
- Positioning of temperature sensors and smoke alarms